

Piab gives you service all over the world.  
To find your local distributor, please visit [www.piab.com](http://www.piab.com).

No need to compromise

[www.piab.com](http://www.piab.com)

Art. No. 0112196, Rev.06  
Piab AB, 2015-08

# MANUAL

## Vacuum pump P6010



(GB) Safety  
(DK) Advarselsymboler  
(DE) Warnsymbole  
(ES) Señales de advertencia  
(FR) Sécurité

(IT) Segnali di avvertenza  
(NL) Waarschuwings-  
symbolen  
(NO) Sikkerhet  
(PT) Sinais Avisadores  
(SE) Säkerhet

(FI) Varoitusmerkit  
(ZH) 安全  
(PL) Bezpieczeństwo  
(RU) Безопасность



- Vacuum force
- Vakuumkraft
- Vakuumkraft
- Fuerza de vacío
- Force d'aspiration
- Potenza di aspirazione
- Vacuumkraft
- Vakuumkraft
- Vácuo ligado
- Vakuumkraft
- Siła ssania
- Voimakas imu
- Сила вакуума
- 真空力



- Exhaust
- Udblæs
- Abluft
- Aire procedente
- Evacuation de l'air
- Aria di scarico
- Uitlaatlucht
- Eksos
- Saida de ar
- Utblås
- Poistoilma
- Wylot
- Выхлоп
- 排気

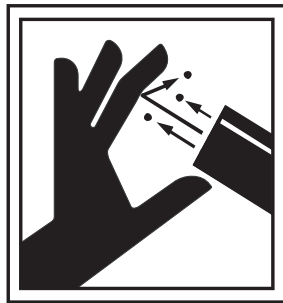

- Unrestricted exhaust
- Forbudt blokere udblæsningerne
- Abluft nicht blockieren
- Prohibido bloquear la salida del aire
- Interdit de bloquer l'évacuation de l'air
- Lo scarico della pompa non deve essere ostruito
- Pompuitlaat vrijhouden
- Forbudt å blokkere eksos
- O escape da bomba deve ser livre
- Förbjudet blockera utblås
- Olospuhalluksen esto kielletty
- Nieograniczony wylot
- Неограниченный выхлоп
- 排気口を塞がないで下さい。

(GB) Warranty  
(DK) Garanti  
(DE) Garantie  
(ES) Garantía

(FR) Garantie  
(IT) Garanzia  
(NL) Garantie  
(NO) Garanti

(PT) Garantia  
(SE) Garanti  
(FI) Takuu  
(日) 保証に関して

(GB) The Piab Vacuum Pump has a 5 year warranty against manufacturing defects. The warranty is valid for the vacuum pump only and covers no other costs.

(DK) Piab vakuumpumper har 5 års garanti mod fabrikationsfejl. Garantien gælder kun vakuumpumperne, men ikke andre omkostninger eller fragtomkostninger.

(DE) Bei Herstellungsfehlern an der Piab Vakuumpumpe geben wir 5 Jahre Garantie. Verschleißteile wie z.B. Filter sind ausgeschlossen.

(ES) La bomba de vacío Piab tiene una garantía de 5 años contra defectos de fabricación. La garantía es válida para la bomba de vacío solamente sin cubrir gastos extras.

(FR) La pompe à vide Piab est garantie 5 ans contre les défauts de fabrication. La garantie est valable uniquement pour la pompe, et ne couvre pas d'autres frais, par exemple les frais d'expédition.

(IT) La pompa a vuoto Piab ha 5 anni di garanzia contro i difetti di fabbricazione. La garanzia è valida solo per la pompa a vuoto e non copre altri costi.

(NL) Piab vacuümpompen hebben een garantietermijn tegen fabricagefouten van 5 jaar. De garantie geldt alleen voor de pomp en dekt geen andere kosten.

(NO) Piab Vakuumpumper har 5 års garanti mot fabrikkasjonsfeil. Garantien gjelder kun vakuumpumperne og dekker ikke andre kostnader eller fraktkostnader.

(PT) As bombas de vacío Piab têm 5 anos de garantia contra defeitos de fabrico. A garantia é válida somente para as bombas de vacío não cobrindo outros custos.

(SE) Piab Vakuumpump har 5 års garanti mot fabrikkationsfel. Garantien omfattar enbart vakuumpumper och täcker ej andra kostnader eller fraktkostnader.

(FI) Piab-tyhjöpumpuilla on 5-vuoden takuu koskien valmistusvirheitä. Takuu koskee ainoastaan tyhjöpumpua, eikä peitä muita kustannuksia taikka lähetyskuluja.

(日) ピアブのポンプには製造上の欠陥に限り五年間の保証があります。保証はポンプのみ有効です。

# 1. INSTALLATION/CONNECTION

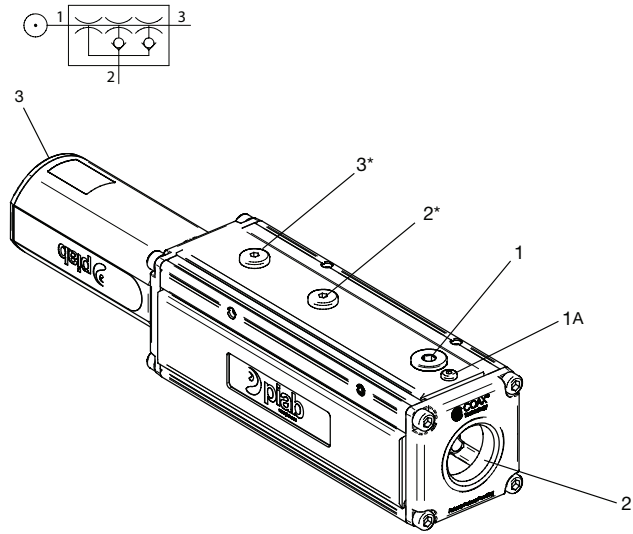

\* Sensing port  
1A Blow-off

## RECOMMENDED HOSE DIMENSIONS IN MM [IN.] (INTERNAL DIAMETER)

Connections		COAX® cartridge Pi			
		1	2	3	4
1.	Compressed air	≥6 [0.24]	≥8 [0.31]	≥10 [0.39]	≥10 [0.39]
2.	Vacuum	≥12 [0.47]	≥15 [0.59]	≥19 [0.75]	≥22 [0.87]
3.	Exhaust	≥15 [0.59]	≥19 [0.75]	≥22 [0.87]	≥25 [0.98]

Applies to hoses up to 2 m (6.6 feet) long.

Connections		COAX® cartridge Si			
		1	2	3	4
1.	Compressed air	≥4 [0.16]	≥6 [0.24]	≥8 [0.31]	≥8 [0.31]
2.	Vacuum	≥12 [0.47]	≥15 [0.59]	≥19 [0.75]	≥22 [0.87]
3.	Exhaust	≥15 [0.59]	≥19 [0.75]	≥22 [0.87]	≥25 [0.98]

Applies to hoses up to 2 m (6.6 feet) long.

Connections		COAX® cartridge Xi			
		1	2	3	4
1.	Compressed air	≥4 [0.16]	≥6 [0.24]	≥8 [0.31]	≥8 [0.31]
2.	Vacuum	≥12 [0.47]	≥15 [0.59]	≥19 [0.75]	≥22 [0.87]
3.	Exhaust	≥15 [0.59]	≥19 [0.75]	≥22 [0.87]	≥25 [0.98]

Applies to hoses up to 2 m (6.6 feet) long.

## FEED PRESSURE, VACUUM LEVEL AND EXHAUST PRESSURE

COAX® cartridge	Feed pressure MPa [psi]	Max. vacuum -kPa [-inHg]	Max. exhaust pressure MPa [psi]
Pi48-3	0.3 [43.5]	90 [26.6]	0.14 [20.3]
Si32-3	0.6 [87]	75 [22]	0.07 [10.2]
Xi40-3	0.45 [65]	96 [28]	0.09 [13.1]

# 2. MOUNTING

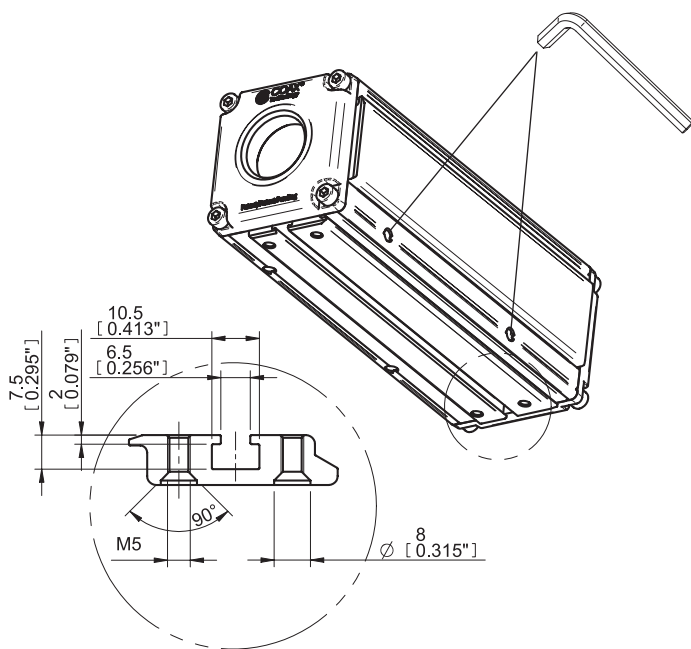

# 3. DIMENSIONS

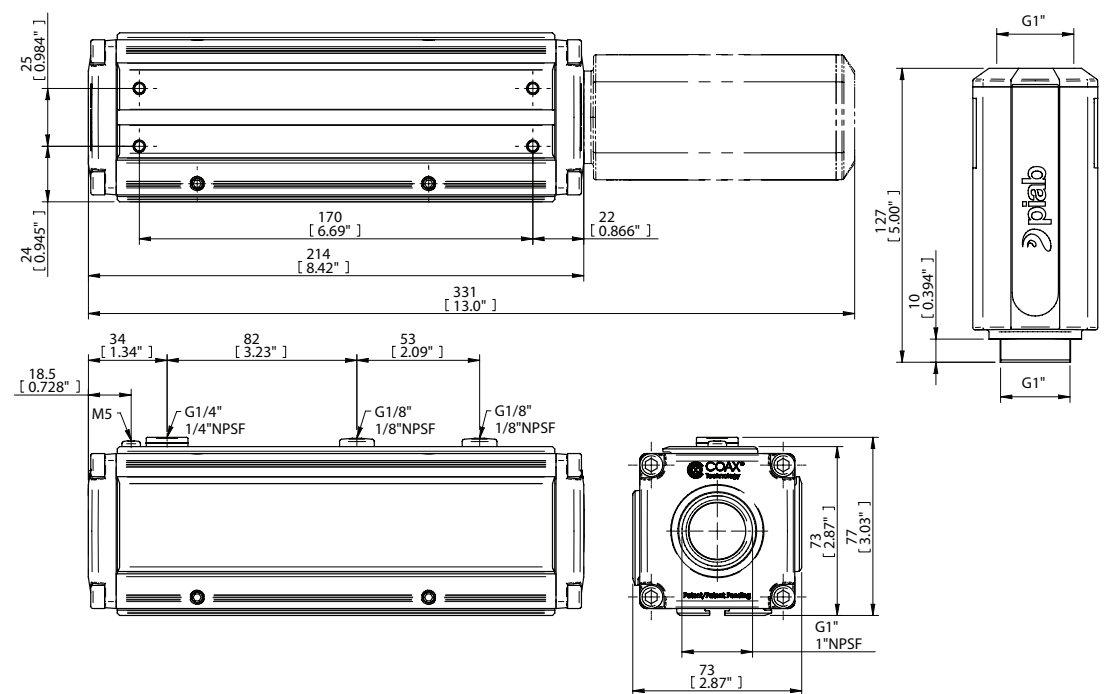

# 4. SPARE PARTS AND ACCESSORIES

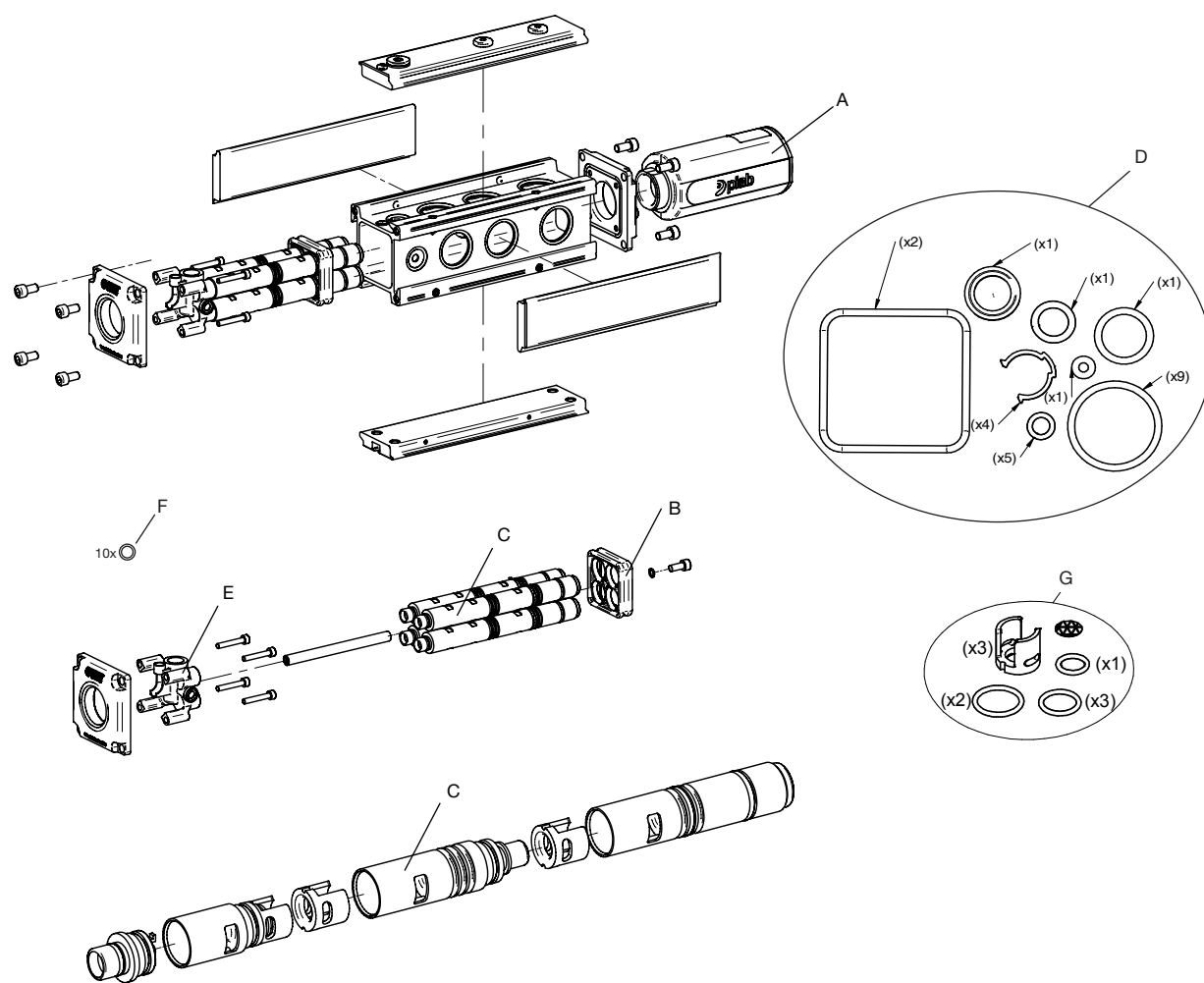

Pos.	Description	Art. No.
A	Silencer G1"	0112499
A	Silencer 1" NPSF	0113003
B	Sealing gable P6010	0112497
C	Vacuum Cartridge Pi48-3	0106639
C	Vacuum Cartridge Pi48-3 A	0107714
C	Vacuum Cartridge Si32-3	0107053
C	Vacuum Cartridge Si32-3 A	0107713
C	Vacuum Cartridge Xi40-3	0118724
C	Vacuum Cartridge Xi40-3 A	0118725
C	Blind Cartridge Midi-3	0112527
D	Spare part kit P6010	0112495
E	Air distributor P6010	0111921
F	Compressed air sealing, P6010	0200655
	Vacuummeter 100 -kPa	0112531
	Manometer 250 -kPa	0112533
	Manometer 1 MPa	0112532
G	Spare part kit Midi COAX® NBR	0109531