

Piab gives you service all over the world.
To find your local distributor, please visit www.piab.com

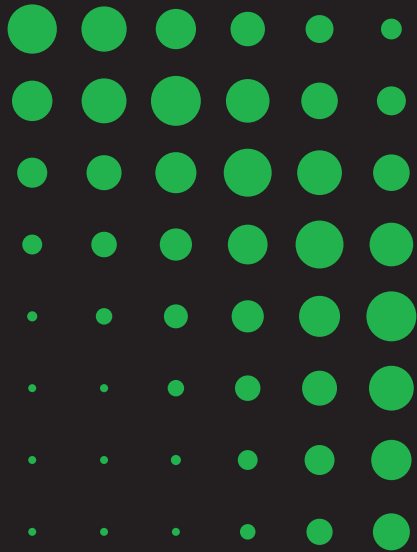

Art. No 0243520, Rev.01
Piab AB, 2022-09

piab Evolving automation

Manual

Tool Changer for the piCOBOT® family

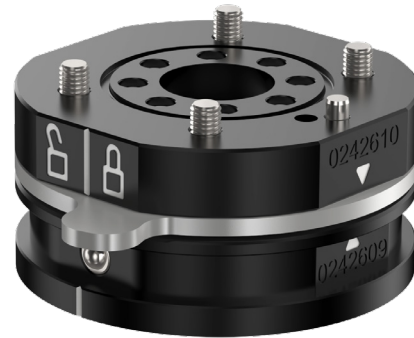

Tool changer and docking station for the piCOBOT® family

The tool changer enables automatic or manual change between gripping tools attached to the piCOBOT® or piCOBOT® L unit. This reduces downtime and increases flexibility when piCOBOT® can pick up different tools from the docking stations to accommodate for different lifting objects. Automatic tool changing is achieved when the tool changer is combined with a docking station.

The tool changer consists of two halves. The tool side half of the tool changer can be mounted to an adjustable gripper, a foam gripper or a custom-built gripping solution.

Ordering information - Spare parts

Art. no.	Description
0243240	Spare part kit O-ring
0242590	Tool changer complete
0242609	Tool changer tool side
0242610	Tool changer pump side

Ordering information - Accessories

Art. no.	Description
0243619	Docking station 105-125
0243620	Docking station 105-165



This manual is available in other languages at piab.com

Tool changer - locking mechanism

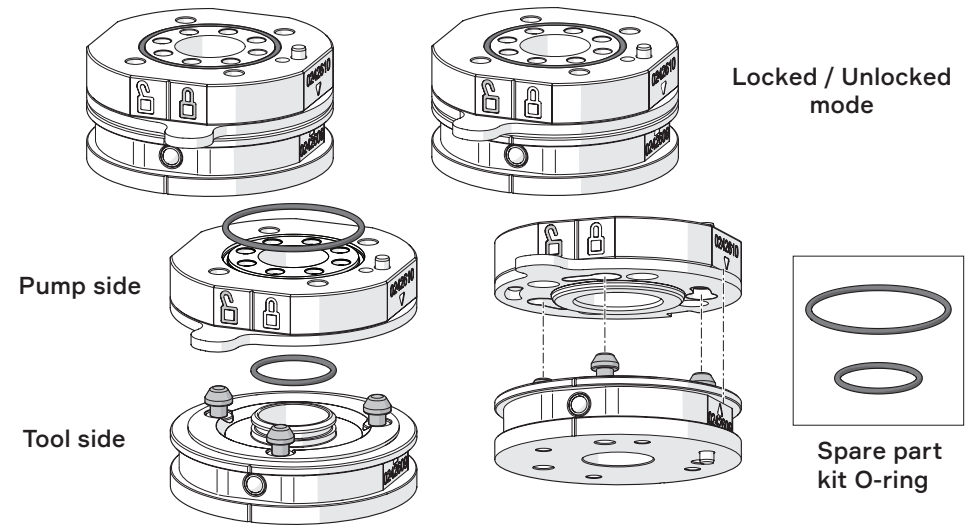

Mounting of tool changer (1) between piCOBOT® and various lifting tools (2)

